

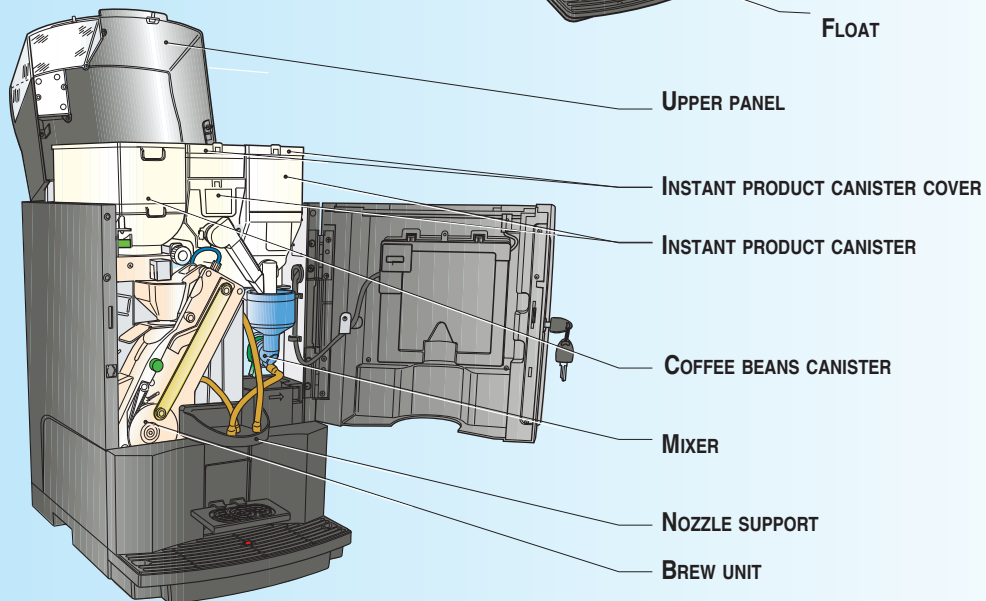

Warnings

*** some models only.**

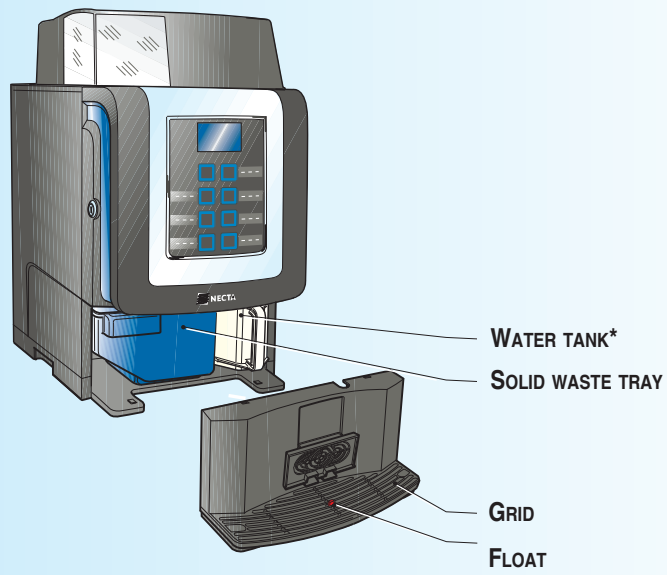
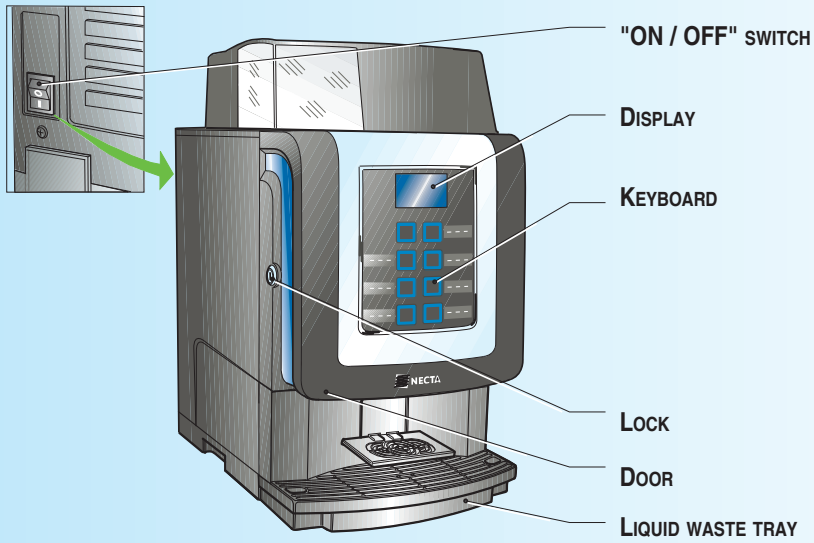

CLEANING AND FILLING

1

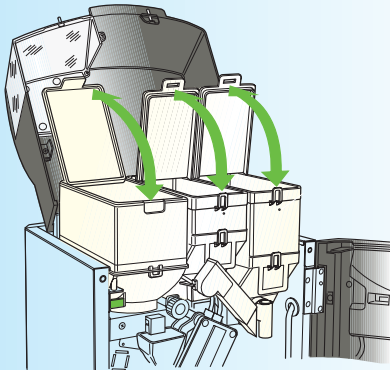

! Make sure that the products to be loaded have been properly preserved and they are not past their sell-by date

Load products:

- Open the vending machine door.
- Lift the upper panel and open the covers of the canisters.
- Load the instant product without compressing powder.
- Load the coffee beans.

2

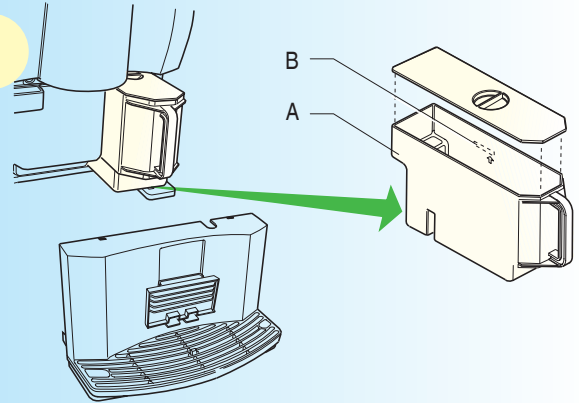

Fill the tank (models with tank only)

- Remove the liquid waste tray.
- Remove the tank (A) by pulling the handle.
- Empty the residual water from the tank and sanitise the tank
- Fill in the tank with drinkable water up to the max level (B).
- Re-position the tank and the liquid waste tray

1

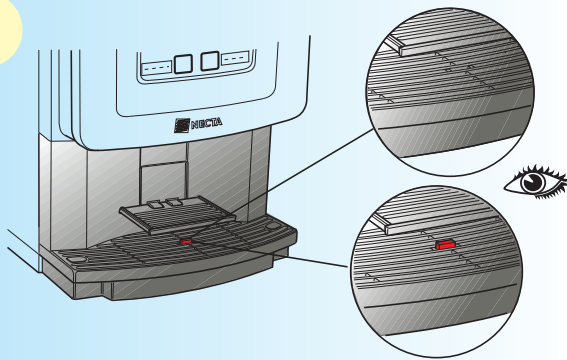

Empty the liquid waste tray

When the float emerges from the grid, promptly empty the liquid waste tray. It is advisable not to wait for the float signal, but to empty the tray at regular intervals.

2

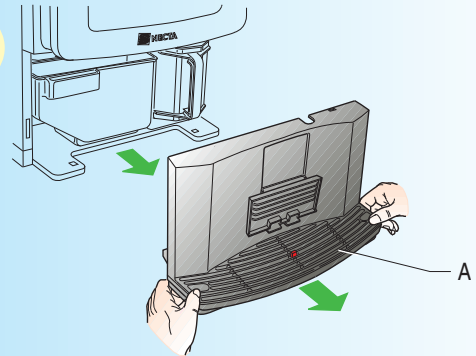

Empty the solid waste tray

- Take the tray (A) by its sides, lift it slightly and pull.
- Empty the tray and wash it with a neutral detergent solution.

3

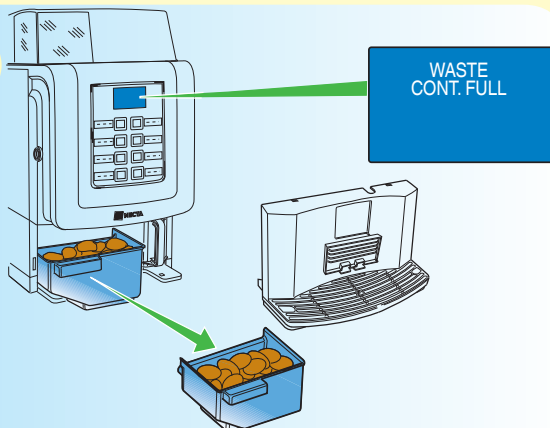

Empty the solid waste tray

- Take the liquid waste tray by its sides, lift it slightly and pull.
- Remove the solid waste tray
- Empty the tray and wash it with a detergent solution.
- Re-position the trays

1

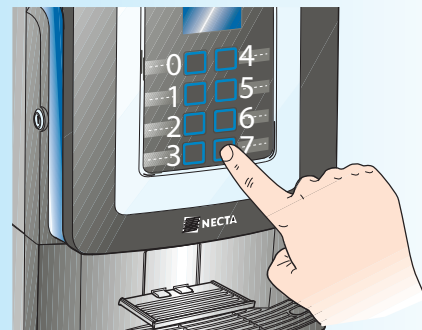

NOTE THE MIXER WASHING PASSWORD

Rinse the mixer

- Hold the last key down for 3 seconds
- Enter the mixer rinse password

Rinse the mixer every day and whenever you load products

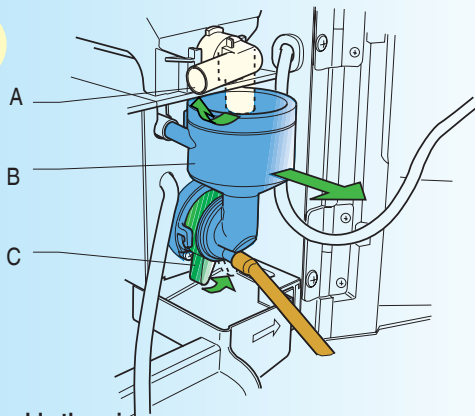
MIXER CLEANING
1

Disassemble the mixer

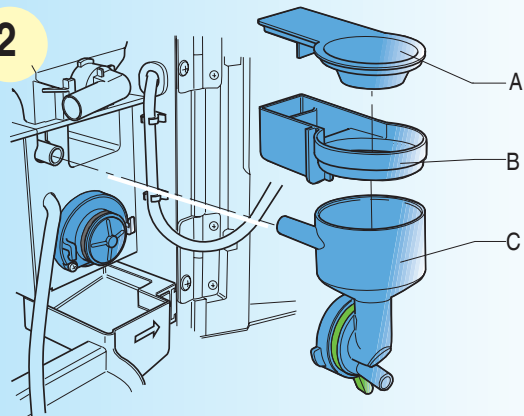
- Detach the tube from the mixer.
- Turn the product dispensing port (A) upwards to facilitate the operation.
- Turn the lever (C) counterclockwise.
- Take the mixer unit (B) and pull.

2

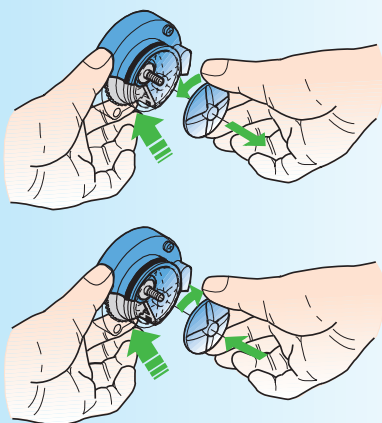
- Detach all components: product funnel (A), powder deposit drawer (B), water funnel (C).
- Disassemble the mixer impeller

3

- Use a finger to hold the toothed disk mounted on the whipper motor firm and unscrew the mixer impeller.
- Wash and rinse all disassembled parts carefully.
- Re-assemble the impeller.

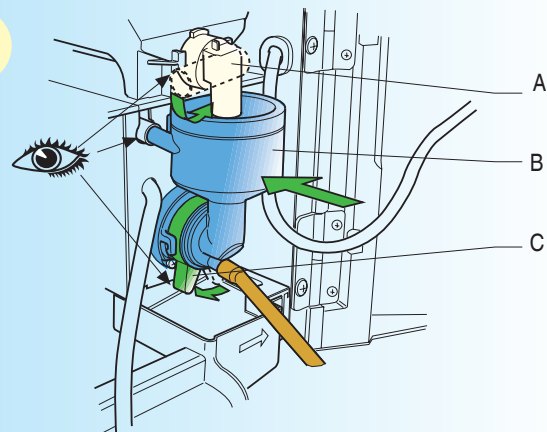
4

Assemble the mixer:

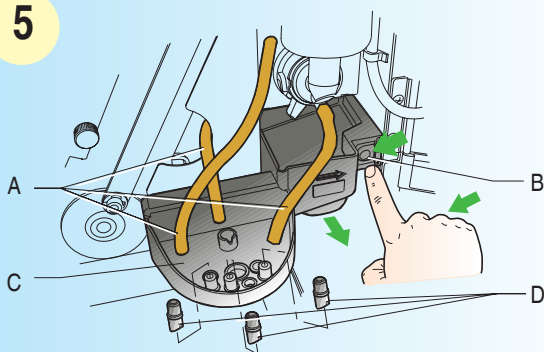
- Re-assemble all mixer components (B).
- Turn the lever (C) clockwise to secure the mixer.
- Turn the port (A) of the instant product downwards
- Re-connect the tube with the mixer.

5

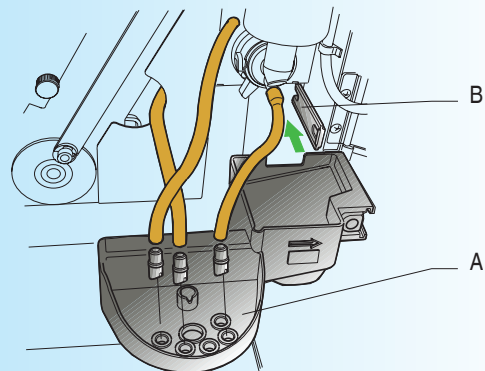
Clean the nozzles:

- Detach the tubes (A) from the nozzles.
- Press the button to release the nozzle support (B).
- Detach the nozzles (D) from the support (C).
- Wash and dry all the parts carefully.

6

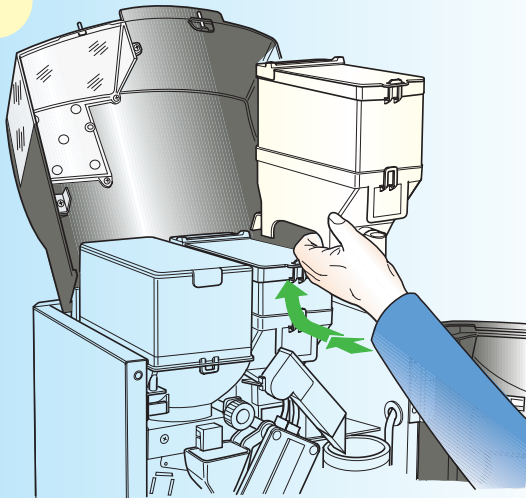
Nozzle support assembly:

- Insert the nozzle support (A) into the guide (B) and push until you hear a click.
- Re-insert the nozzles in the support and re-connect the tubes with the relative nozzles.

COMPLETE CLEANING
1

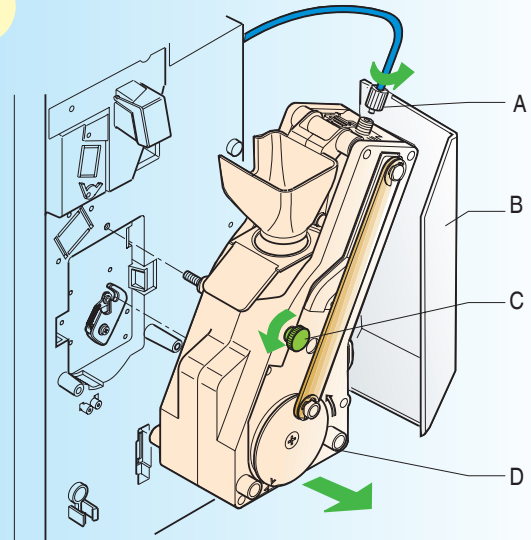
Instant canister:

- Open the vending machine door and lift the upper panel.
- Push slightly inside and lift the canister.
- Remove the canister from the machine
- Dust the canister and the base carefully.
- Re-position the canister into its seat.

2

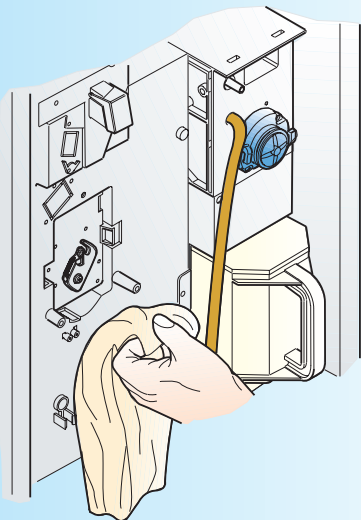
Cleaning the brew unit:

- Unscrew the ring nut (A) and pay attention not to lose the gasket.
- Remove the coffee waste conveyor (B), if any.
- Unscrew the pin (C).
- Remove the brew unit (D).

3

Clean inside the machine with a neutral detergent solution by using a piece of cloth that is slightly wet.



Never use any water jet.

To avoid any risk of chemical oxidation or corrosion in general, use neutral detergents and avoid any solvent.

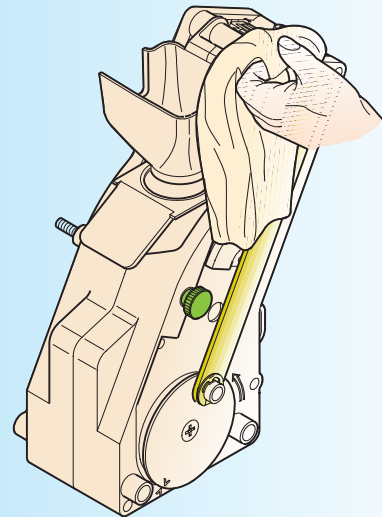
4

Cleaning the brew unit

- Whenever you load or at least every week, it is recommended to remove any coffee residual from around the brew unit.
- Rinse the brew unit beneath a water jet.
- Rinse the unit carefully.
- Re-assemble the unit by carrying out the operations in the reverse order.